

Battery charging systems

for auto battery charging on the assembly line

Sickert & Hafner GmbH

Automotive systems

Berliner Strasse 9
63628 Bad Soden-Salmuenster
Germany

Phone +49 (0) 6056/90057-0
Fax +49 (0) 6056/90057-11
E-mail sales@sickert-hafner.de
Web www.sickert-hafner.de

Battery charging systems

Sickert & Hafner auto battery charging systems allow you to keep vehicle batteries charged while vehicles are on the assembly line.



These systems are ideally suited for vehicle finishing and testing phases, in situations that allow for support of the vehicle's on-board battery by a battery charging device.

Sickert & Hafner battery charging solutions can also be used as external power sources when testing needs to be carried out and the vehicle's battery has not yet been installed.

Solutions

The following battery charging systems can be realized:

- Gravity conveyors
- Synchronous conveyors
- MBO systems

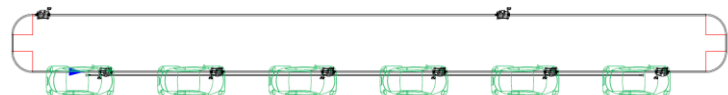

The suitability of a specific system for a specific setting is determined by the characteristics of and structures in the production facility, as well as your goals, specifications, and budget.

All of our battery charging solutions are tailored to the customer's needs, which means that we can modify and combine the elements of our various systems. For example, a gravity conveyor can be fitted with an automatic chain driven conveyor element for return movement.

System components

All of our solutions are based on the following core components:

Conveyor systems

Our conveyor systems are made of SH120 aluminum profiles, which are both lightweight and versatile. Thus for example, forward and backward movement of the chain can be realized within a single profile via a reversal mechanism. Moreover, all systems can integrate an optional servicing area that allows the battery charging units to be removed and serviced right at the conveyor.

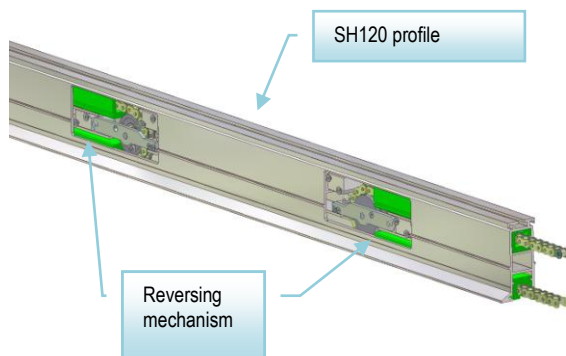

Battery charging units

Typical battery charging unit (BCU) components:

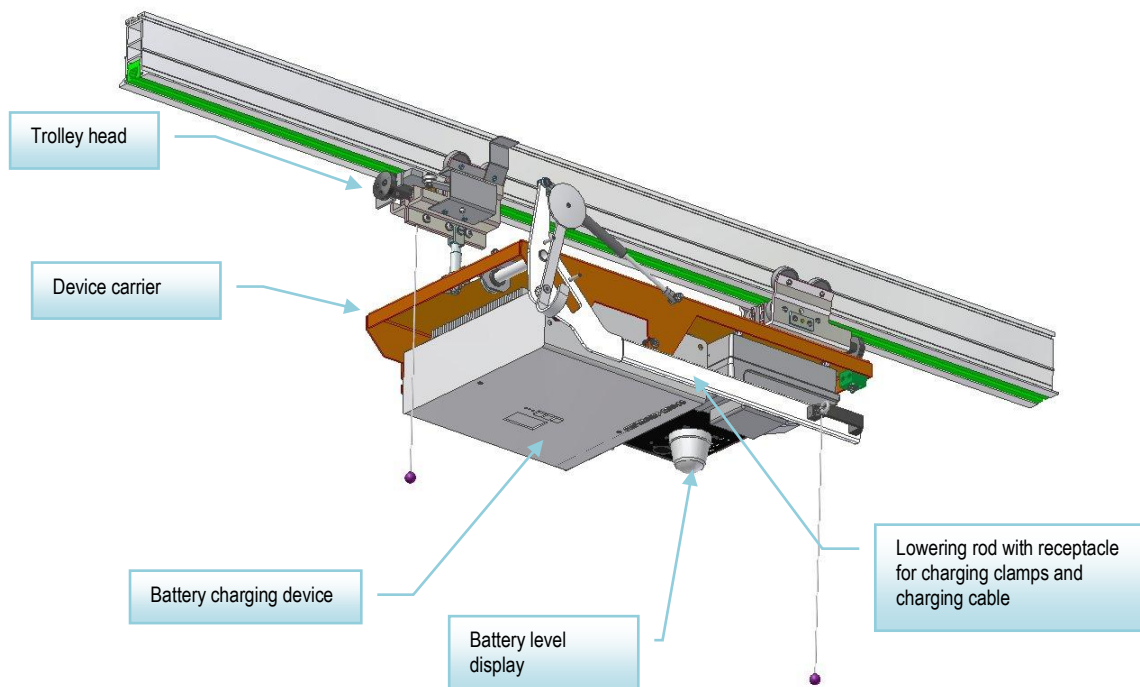

Additional components may also be needed depending on the system concerned (e.g. for MBO controllers and sensors).

Application domain

Thanks to our lightweight SH120 aluminium profiles, our systems can be deployed in light tunnels and other lightweight factory installations. Our battery charging systems are also very squat, thus allowing for their use in light tunnels with low clearance.

In addition to deployment in front-loaded synchronous floor conveyors that carry only one type of vehicle, our battery charger systems are also suitable in situations where...

- vehicles of differing lengths need to be kept charged while on a floor conveyor
- both front and rear loading needs to be carried out
- a floor conveyor's cycle lengths vary



All systems can be realized with an optional servicing area that allows the battery charging units to be removed and serviced right at the conveyor.

Sickert & Hafner GmbH

Automotive systems

Berliner Strasse 9
63628 Bad Soden-Salmuenster
Germany

Phone +49 (0) 6056/90057-0
Fax +49 (0) 6056/90057-11
E-mail sales@sickert-hafner.de
Web www.sickert-hafner.de